

BS&B SAFETY SYSTEMS, INC.
BS&B SAFETY SYSTEMS LTD

Installation Instructions

Bulletin 77-4009I

See our Internet site at
www.bsbsystems.com or
www.bsb.ie for updates!

Types CSI™ and CSR™ Rupture Disks CSR-7RS™ Safety Head

Warning: Rupture disks are intended to provide a pressure relief opening. This rupture disk is designed to burst at a specified temperature and pressure, thereby relieving excess pressure or preventing excessive vacuum in a system. **It is imperative that this rupture disk be properly installed and safely vented in order to avoid bodily injury, damage to property, pollution and loss of product.** BS&B Safety Systems, Inc. and BS&B Safety Systems Ltd. supply disks selected by their customers, which are manufactured in reliance upon information and specifications supplied by the customer. BS&B Safety Systems, Inc. and BS&B Safety Systems Ltd. are not liable for any damage resulting from improper installation, improper system design, unsafe venting, or other factors beyond BS&B Safety Systems, Inc. and BS&B Safety Systems Ltd. control. Do not locate the rupture disk device where personnel, equipment or property will be exposed to released product and pressure through the disk. Handle carefully, disk and tag may have sharp edges.

Order Replacement Disks by Lot Number (Shown on disk's tag). Before you Install a Rupture Disk

1. Inspect Safety Head (Rupture Disk Holder)

Inspect Safety Head's mating surfaces for foreign material. Pits, dust or grit can damage the rupture disk affecting disk performance or cause leakage. If surfaces are rough, polish with a fine emery cloth. Clean as necessary. Do NOT machine Safety Head; dimensions are critical. Inspect Safety Head bore for product build-up (plating) and corrosion. Clean when necessary. Do not re-machine or use a damaged Safety Head.

The Safety Head size and pressure rating must match the companion pipe flange size and rating. Ensure appropriate adjustments are made for temperature when reviewing flange rating compatibility.

2. Inspect Pipe Flanges

Ensure the pipe companion (mating) flanges are parallel. Non-parallel flanges can significantly change anticipated performance of rupture disk devices.

3. Inspect Rupture Disk

Prior to assembly, ensure the model/type of Safety Head to be used is compatible with the rupture disk type. For 'CE' marked disks, the disk tag identifies the Safety Head types that may be used. The rupture disk burst pressure must not exceed the Safety Head and pipe flange rating. Handle the rupture disk carefully, holding the disk by the tag and the disk rim only. Examine both sides of the disk checking the seating and domed surfaces for nicks, dents, scratches and foreign material which can damage the disk, cause leakage or affect the burst pressure. Do not install a damaged disk. Installation of a damaged disk may result in premature activation of the disk. If damaged or misinstalled (upside down), the CSR or CSI will not exceed its marked burst pressure.

Safety Precautions - Caution

- ◆ Only competent, trained personnel should install rupture disk safety devices in accordance with these installation instructions.
- ◆ Consider recoil. Provide adequate support for piping and connections to absorb recoil/reaction forces when the disk ruptures. Recoil is the force the system will experience upon disk rupture. Recoil (lbs) is approximately twice the disk's burst pressure (psig) times the relief area (sq. in.). If the discharge is free-vented, a baffle plate may be mounted down-stream of the outlet companion pipe flange with extra length studs to absorb recoil.
- ◆ Do not remove rupture disks from packaging for inspection until ready to install.
- ◆ The rupture disk and Safety Head should not be subjected to excessive structural bending stresses.
- ◆ Should cleaning be required, care must be taken to prevent damage to the disk. If liquid or steam cleaning is used, ensure no particle spray or jet comes in contact with the crown of the disk.
- ◆ Do not locate the disk where it may be subjected to thermal shock. Moisture, rain, condensation or snow may cause a thermal shock to the disk causing the disk to activate below its marked burst pressure. A protector is recommended for temperatures above 212°F (100°C), consult BS&B Safety Systems, Inc. or BS&B Safety Systems Ltd.

(continued on page 2)

(continued from page 1)

- ◆ Where a disk is mounted upstream of a pressure relief or safety valve, ensure the opening of the disk does not interfere or effect the performance of the valve.
- ◆ When the disk ruptures, ensure the opening of the disk does not affect the performance of downstream equipment. The bursting of a disk may result in a pressure shockwave.
- ◆ Do not reinstall a disk that has been removed from the piping system unless used in a pre-torqued Safety Head. When stresses in the disk are relieved by removing it from the Safety Head, the disk can never resume its original installed condition which can affect disk performance.
- ◆ Only pre-torqued Safety Heads (CSR-7RS™) with the

contained rupture disk may be removed from service and re-installed provided the capscrews are not loosened, the capscrew torque is maintained and the disk is in good condition.

- ◆ The rupture disk and Safety Head must not be machined or modified in any way except with the approval of BS&B Safety Systems, Inc. or BS&B Safety Systems Ltd. Failure to obtain such approval voids the warranty on this product.
- ◆ Safety Head and rupture disk materials should be compatible with your process.
- ◆ Corrosion and process conditions may deteriorate disk performance and necessitate frequent replacement.

Installation of Rupture Disk in CSR-7RS™ Safety Head (Refer to Figure 1)

1. Place inlet of Safety Head on a flat work surface in position as shown with flow arrows and locating pins up. (Please refer to the drawing in Figure 1 that corresponds to the nominal disk size and Safety Head rating to be installed)
2. Place NEW, UNDAMAGED, rupture disk on inlet so locating pins mate with the corresponding holes in the rim of the rupture disk.
3. Carefully align and place Safety Head outlet flange in position as shown. Ensure flow arrows on the Safety Head point in the required direction of flow during pressure relief.
4. Assemble unit with 12-point capscrews provided with Safety Head. Using a 12-point socket, tighten the capscrews finger tight prior to beginning the torquing process. DO NOT SUBSTITUTE capscrews supplied. Do not lubricate blue fluoropolymer-coated capscrews.
5. Evenly torque the capscrews to the value shown in Table A when using uncoated capscrews or Table B when using blue color fluoropolymer-coated capscrews.

Torque evenly in a cross or star pattern by applying 1/4 of the torque value to capscrew (1), and then applying torque to (2), (3) and (4) etc. Repeat the torquing pattern for 1/2 then 3/4 of the recommended torque value. Finally, using same pattern, torque to full torque value. Note: Improper torquing can cause disk rupture below its marked burst pressure. Excessive torquing can cause damage to the disk and Safety Head. Use the correct socket and torque wrench with appropriate torque value range. The torque wrench must be calibrated.

6. The 12-point capscrew heads should be recessed into the CSR-7RS™ Safety Head outlet after installation.
7. Sizes 2" (50mm) and above have a "bite type" seal on the CSR-7RS™ inlet face that engages with the rupture disk. Do not modify this feature in any way. Should the "bite type" seal be incomplete or damaged, contact BS&B Safety Systems, Inc. or BS&B Safety Systems Ltd. for repair.

Installation of Safety Head CSR-7RS™ Assembly in Pressure System (Refer to Figures 2 and 3)

1. Insert the Safety Head assembly into the pressure system between companion flanges. Ensure flow arrows on the Safety Head point in the desired flow direction. The CSR-7RS™ centers inside the bolt circle of the pipe flanges and a J-Bolt prevents the Safety Head from being installed incorrectly with respect to direction, see Fig 3. The inlet companion flange must be radially drilled to accept the J-Bolt. Table E lists companion flange drilling dimensions. Locate the J-Bolt in the drilled hole. Do not remove or damage the J-Bolt.
2. Install gaskets between the Safety Head and the companion flanges. We recommend a compressed fiber gasket 1/16" (1.5 mm) or 1/8" (3 mm) thick. The user is cautioned to select gasket materials adequate for the service conditions including the ability of the gasket to resist "cold flow". Gaskets that cold flow will allow torque relaxation affecting their sealing performance. (The burst pressure of disks installed in pre-torqueable

Safety Heads CSR-7RS™ is unaffected.) Contact BS&B Safety Systems, Inc. or BS&B Safety Systems Ltd. if an alternative gasket type is used.

3. Install studs with nuts. Studs with nuts should be free running with lightly oiled threads, see Table D for stud details. Tighten all nuts finger tight. Torque the nuts to the value shown in Table C. Torque evenly in a diagonal pattern by applying 1/4 of the recommended torque to each stud. Repeat pattern by torquing to 1/2 then 3/4 of the recommended torque value. Then using same pattern, torque to full torque value. Do not exceed the specified torque value.
4. The torque value on the companion flange nuts should be verified periodically.

The following Patents apply: **CSI™** and **CSR™** US 5,167,337 and worldwide patents. US and worldwide patents pending. **CSR-7RS™** US 4,751,938, 5,005,722, 5,305,775 and worldwide patents.

TORQUE TABLE A - Uncoated Capscrews
CSR-7RS™ Pre-assembly capscrew torque

SIZE		SAFETY HEAD FLANGE RATING			PREASSEMBLY CAPSCREW TORQUE		12 POINT SOCKET SIZE	SOCKET DRIVE *	SUGGESTED SOCKET SOURCE SNAP-ON TOOLS
					ALL TYPES				
					ALL MATERIALS				
IN	MM	ANSI	DIN	JIS	FT-LB	NT-M	IN	IN	
1	25	150	10/16	10/16	11	15	1/4	3/8	SF-081
1	25	300/600	25/40	20/30/40	17	23	1/4	3/8	SF-081
1 1/2	40	150	10/16	10/16	20	27	5/16	3/8	SF-101
1 1/2	40	300/600	25/40	20/30/40	30	41	5/16	3/8	SF-101
2	50	150	10/16	10/16	26	35	5/16	3/8	SF-101
2	50	300/600	25/40	20/30/40	34	46	5/16	3/8	SF-101
3	80	150	10/16	10/16	41	55	3/8	3/8	SF-121
3	80	300/600	25/40	20/30/40	65	88	3/8	3/8	SF-121
4	100	150	10/16	10/16	75	102	7/16	3/8	SF-141
4	100	300	25/40	20/30/40	102	138	7/16	3/8	SF-141
4	100	600	—	—	53	72	3/8	3/8	SF-121
6	150	150	10/16	10/16	47	64	3/8	3/8	SF-121
6	150	300	25/40	20/30/40	60	81	3/8	3/8	SF-121
6	150	600	—	—	97	132	7/16	3/8	SF-141
8	200	150	—	—	70	95	7/16	3/8	SF-141
8	200	300	—	—	84	114	7/16	3/8	SF-141

The torque values in the table above are based on the assumption of lightly oiled, clean, free running threads with a coefficient of friction of $\mu=0.16 - 0.20$. The affects of corrosion, the use of particular thread compounds, or dry assembly may result in a change in the effective clamp load on the disk assembly. This may adversely affect the performance of the disk.

TORQUE TABLE B - Blue Coated Capscrews
CSR-7RS™ Pre-assembly capscrew torque

(Blue Coated Capscrews, Max Temperature 500 °F, 260 °C)

SIZE		SAFETY HEAD FLANGE RATING			PREASSEMBLY CAPSCREW TORQUE		12 POINT SOCKET SIZE	SOCKET DRIVE *	SUGGESTED SOCKET SOURCE SNAP-ON TOOLS
					ALL TYPES				
					ALL MATERIALS				
IN	MM	ANSI	DIN	JIS	FT-LB	NT-M	IN	IN	
1	25	150	10/16	10/16	6	8	1/4	3/8	SF-081
1	25	300/600	25/40	20/30/40	9	12	1/4	3/8	SF-081
1 1/2	40	150	10/16	10/16	10	14	5/16	3/8	SF-101
1 1/2	40	300/600	25/40	20/30/40	15	20	5/16	3/8	SF-101
2	50	150	10/16	10/16	13	18	5/16	3/8	SF-101
2	50	300/600	25/40	20/30/40	17	23	5/16	3/8	SF-101
3	80	150	10/16	10/16	21	28	3/8	3/8	SF-121
3	80	300/600	25/40	20/30/40	33	45	3/8	3/8	SF-121
4	100	150	10/16	10/16	38	52	7/16	3/8	SF-141
4	100	300	25/40	20/30/40	51	69	7/16	3/8	SF-141
4	100	600	—	—	27	37	3/8	3/8	SF-121
6	150	150	10/16	10/16	24	33	3/8	3/8	SF-121
6	150	300	25/40	20/30/40	30	41	3/8	3/8	SF-121
6	150	600	—	—	49	66	7/16	3/8	SF-141
8	200	150	—	—	35	47	7/16	3/8	SF-141
8	200	300	—	—	42	57	7/16	3/8	SF-141

Do not lubricate blue fluoropolymer coated capscrews.

*12 point, deep length, thinwall socket. Snap-On® is a registered trademark of Snap-On Technologies Incorporated.

Figure 1: Safety Head Type CSR-7RS™

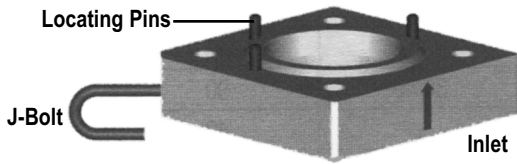
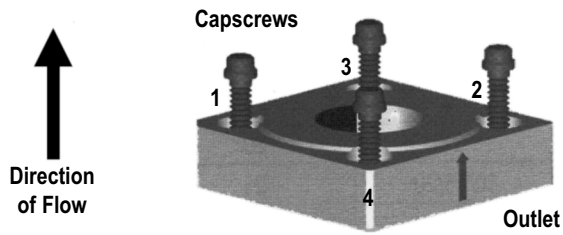

1" (25mm)	ANSI	150/300/600
1-1/2" (40mm)	DIN	10/16/25/40
	JIS	10/16/20/30/40

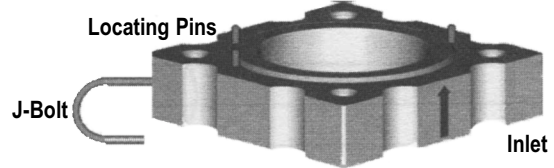
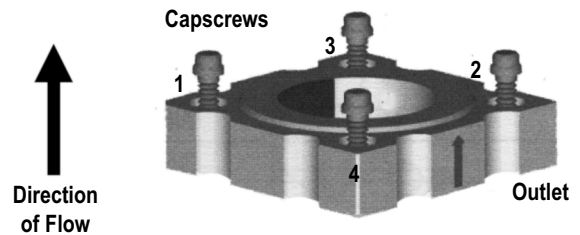

2" (50mm)	ANSI	150/300/600
3" (80mm)	DIN	10/16/25/40
4" (100mm)	JIS	10/16/20/30/40
Except for:		
4" (100mm)	ANSI	600

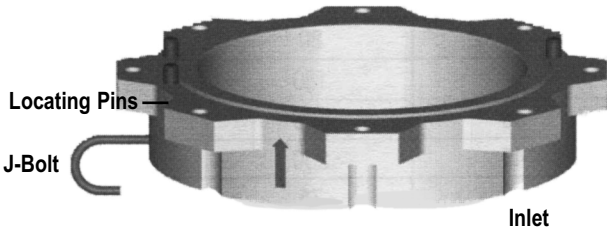
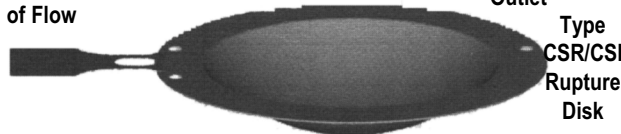
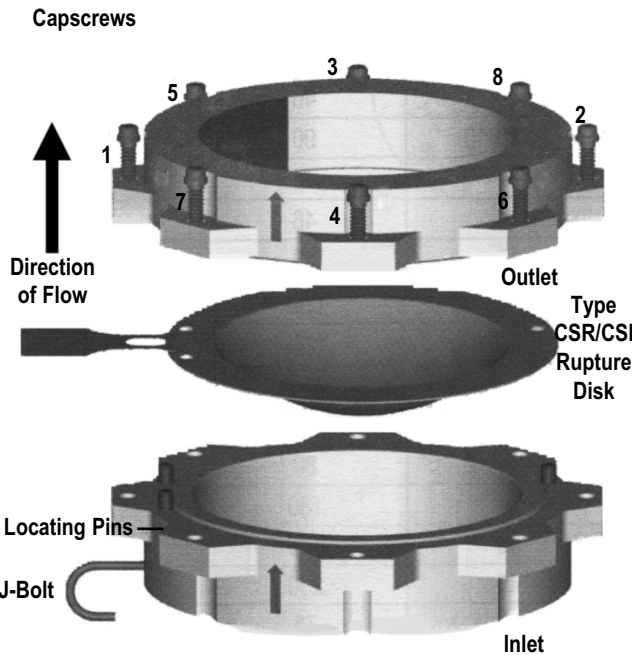

6" (150mm)	ANSI	150/300
	DIN	10/16/25/40
	JIS	10/16/20/30/40

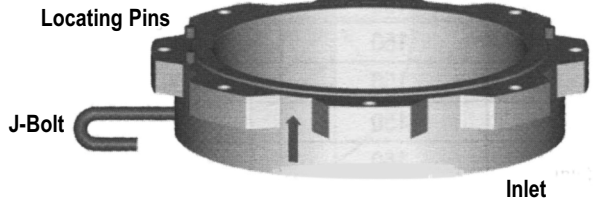
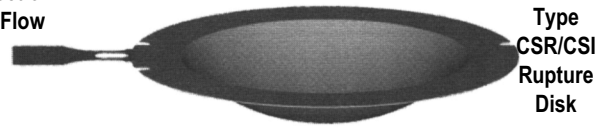
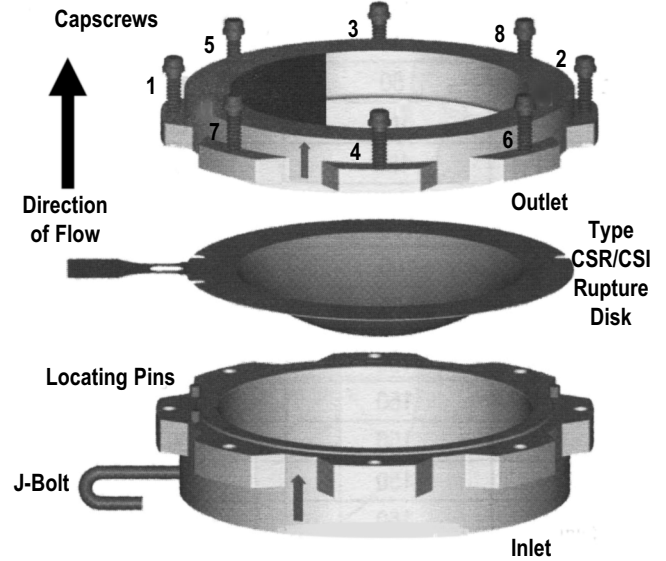

8" (200mm)	ANSI	150/300
	DIN	10

TORQUE TABLE C
CSR-7RS™
COMPANION FLANGE TORQUE

SIZE		COMPANION FLANGE RATING			FLANGE STUD TORQUE	
IN	MM	ANSI	DIN	JIS	FT-LB	NT-M
1	25	150	10/16	-	20	27
1	25	-	-	10/16/20	43	58
1	25	-	25/40	-	22	30
1	25	300/600	-	-	40	54
1	25	-	-	30/40	43	58
1.5	40	150	-	-	25	34
1.5	40	-	10/16	10/16/20	46	62
1.5	40	300/600	-	-	82	111
1.5	40	-	25/40	-	49	66
1.5	40	-	-	30/40	92	125
2	50	150	-	-	40	54
2	50	-	10/16	10	50	68
2	50	-	-	16	46	62
2	50	300/600	-	-	48	65
2	50	-	25/40	-	53	72
2	50	-	-	20/30/40	46	62
3	80	150	-	-	50	68
3	80	-	10/16	10	46	62
3	80	-	-	16/20	90	122
3	80	300/600	-	-	92	125
3	80	-	25/40	-	50	68
3	80	-	-	30/40	92	125
4	100	150	-	-	45	61
4	100	-	10/16	10	47	64
4	100	300	-	16/20	90	122
4	100	-	25/40	-	98	133
4	100	600	-	-	152	206
4	100	-	-	30/40	125	169
6	150	150	-	-	75	102
6	150	-	10/16	-	94	127
6	150	-	-	10	110	149
6	150	-	-	16/20	124	168
6	150	300	-	-	84	114
6	150	600	-	-	212	287
6	150	-	-	30	155	210
6	150	-	25/40	-	173	235
6	150	-	-	40	295	400
8	200	150	-	-	80	108
8	200	300	-	-	140	190

The above torque values are suitable for use with studs of a minimum design stress of 25,000 psi as defined in ASME Section II Table 3. The companion flanges must be compatible for use with stud stresses up to 25,000 psi. Consult BS&B Safety Systems, Inc. or BS&B Safety Systems Ltd for flanges in other materials when suppliers recommend torque values lower than the BS&B Safety Systems, Inc. or BS&B Safety Systems Ltd recommended torque values and if gasket type differs from BS&B Safety Systems, Inc. or BS&B Safety Systems Ltd recommendations.

The torque values in the table above are based on the assumption of lightly oiled, clean free running threads with a co-efficient of friction of $\mu = 0.16 - 0.20$. The customer is advised that the effects of corrosion, the use of particular thread compounds or dry assembly, may result in a change in the effective clamp load on the disk assembly. This may adversely affect the performance of the bursting disk device.

Torque values are based on the use of compressed fiber gaskets.

Figure 2: CSR-7RS™ Safety Head Companion Flange Bolting Pattern
 (Capscrews removed for clarity)
 Refer to the drawing that corresponds to the Safety Head Size and Flange Rating

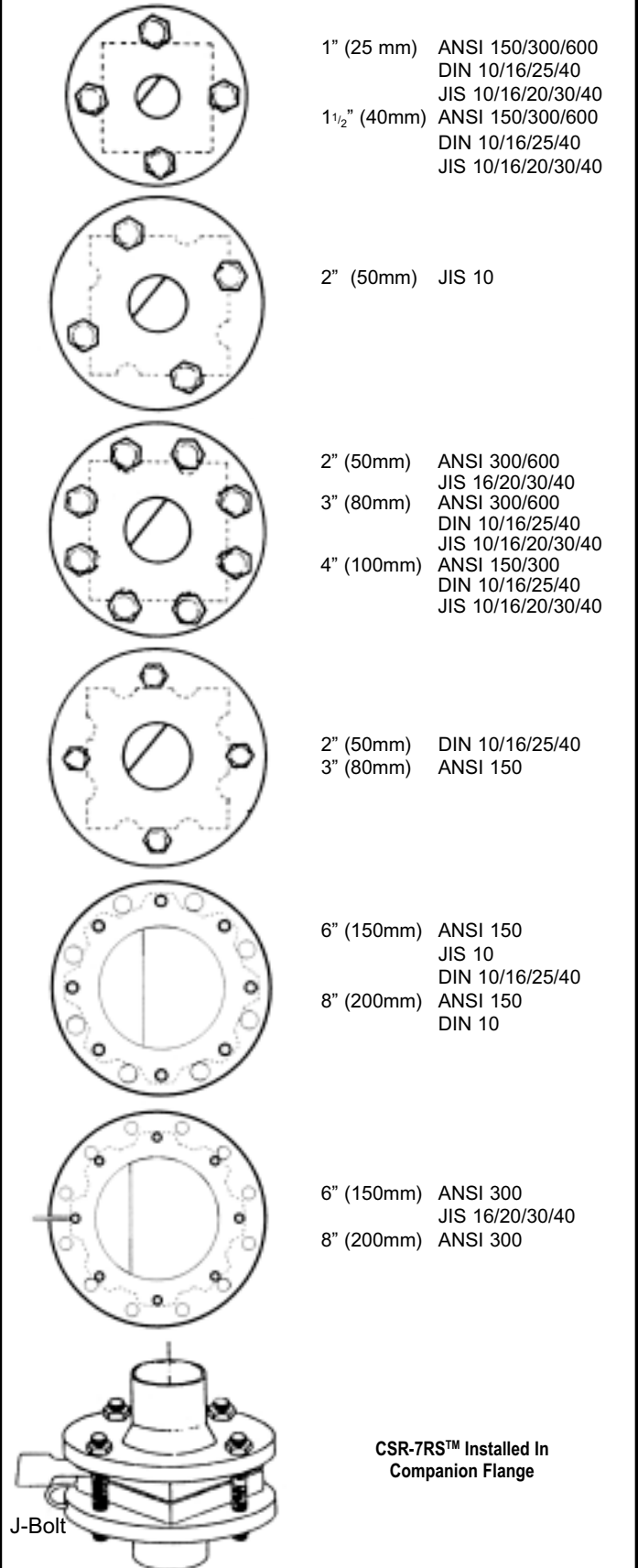

TORQUE TABLE D
CSR-7RS™
COMPANION FLANGE STUDS

SIZE		COMPANION FLANGE RATING			# OF STUDS	DIAMETER OF STUD		MIN. LENGTH OF STUD	
IN	MM	ANSI	DIN	JIS		IN	MM	IN	MM
1	25	150	-	-	4	1/2	-	4-1/2	-
1	25	300	-	-	4	5/8	-	5-1/2	-
1	25	600	-	-	4	5/8	-	5-1/2	-
1	25	-	10/16/25/40	-	4	-	12	-	125
1	25	-	-	10/16/20	4	-	16	-	135
1	25	-	-	30/40	4	-	16	-	135
1 1/2	40	150	-	-	4	1/2	-	5	-
1 1/2	40	300/600	-	-	4	3/4	-	6-1/2	-
1 1/2	40	-	10/16/25/40	-	4	-	16	-	135
1 1/2	40	-	-	10/16/20	4	-	16	-	140
1 1/2	40	-	-	30/40	4	-	20	-	150
2	50	150	-	-	4	5/8	-	6-1/2	-
2	50	300	-	-	8	5/8	-	6-1/2	-
2	50	600	-	-	8	5/8	-	6-1/2	-
2	50	-	10/16/25/40	-	4	-	16	-	145
2	50	-	-	10	4	-	16	-	140
2	50	-	-	16/20	8	-	16	-	140
2	50	-	-	30/40	8	-	16	-	155
3	80	150	-	-	4	5/8	-	6-1/2	-
3	80	300	-	-	8	3/4	-	7-1/2	-
3	80	600	-	-	8	3/4	-	7-1/2	-
3	80	-	10	-	8	-	16	-	155
3	80	-	16/25/40	-	8	-	16	-	160
3	80	-	-	10	8	-	16	-	155
3	80	-	-	16/20	8	-	20	-	165
3	80	-	-	30/40	8	-	20	-	185
4	100	150	-	-	8	5/8	-	7-1/2	-
4	100	300	-	-	8	3/4	-	8-1/2	-
4	100	600	-	-	8	7/8	-	8	-
4	100	-	10/16	10	8	-	16	-	180
4	100	-	25/40	-	8	-	21	-	185
4	100	-	-	16/20	8	-	20	-	195
4	100	-	-	30/40	8	-	22	-	210
6	150	150	-	-	8	3/4	-	8-3/4	-
6	150	300	-	-	12	3/4	-	9-1/2	-
6	150	600	-	-	12	1	-	10-1/2	-
6	150	-	10/16	-	8	-	21	-	205
6	150	-	25/40	-	8	-	25	-	225
6	150	-	-	10	8	-	20	-	205
6	150	-	-	16/20	12	-	22	-	235
6	150	-	-	30	12	-	24	-	245
6	150	-	-	40	12	-	30	-	270
8	200	150	-	-	8	3/4	-	9	-
8	200	300	-	-	12	7/8	-	10	-

This data assumes the use of a standard specification CSR-7RS Safety Head as indicated in Catalog 77-4009.

TABLE E
CSR-7RS™ ASSEMBLY COMPANION FLANGE “J” BOLT DRILLING DIMENSIONS

SIZE		COMPANION FLANGE RATING			DIMENSIONS - A		DIMENSIONS - B		DIMENSIONS - C	
IN	MM	ANSI	DIN	JIS	IN +/- 1/32	MM +/- .8	IN + 1/16-0	MM - 1.6-0	IN	MM
1	25	150	-	-	5/16	8	7/16	11	3/8	9.5
1	25	-	10/16	-	13/32	10	5/16	8	7/16	11
1	25	-	-	10/16	9/32	7	35/64	14	7/16	11
1	25	300	-	-	7/16	11	1/2	13	3/8	9.5
1	25	-	25	-	13/32	10	5/16	8	7/16	11
1	25	-	-	20	9/32	7	5/8	16	7/16	11
1	25	600	-	-	1/2	13	5/8	16	3/8	9.5
1	25	-	40	-	13/32	10	35/64	14	7/16	11
1	25	-	-	30/40	13/32	10	6/8	16	7/16	11
1 1/2	40	150	-	-	3/8	9.5	7/16	11	7/16	11
1 1/2	40	-	10/16	-	13/32	10	13/32	10	7/16	11
1 1/2	40	-	-	10/16/20	11/32	9	5/8	16	7/16	11
1 1/2	40	300	-	-	1/2	13	1/2	13	7/16	11
1 1/2	40	-	25/40	-	13/32	10	13/32	10	7/16	11
1 1/2	40	-	-	30/40	7/16	11	19/32	15	7/16	11
1 1/2	40	600	-	-	9/16	14.5	1/2	13	7/16	11
2	50	150	-	-	7/16	11	7/16	11	7/16	11
2	50	-	-	10/16/20	13/32	10	7/16	11	7/16	11
2	50	-	10/16/25/40	-	15/32	12	19/32	15	7/16	11
2	50	-	-	30/40	15/32	12	5/8	16	7/16	11
2	50	300/600	-	-	9/16	14.5	11/16	17.5	7/16	11
3	80	150	-	-	5/8	16	7/16	11	7/16	11
3	80	-	-	10	13/32	10	13/32	10	7/16	11
3	80	-	10/16/25/40	-	15/32	12	13/32	10	1/2	13
3	80	-	-	16/20	1/2	13	11/32	9	7/16	11
3	80	300/600	-	-	5/8	16	13/16	20.5	7/16	11
3	80	-	-	30/40	1/2	13	19/32	15	7/16	11
4	100	150	-	-	5/8	16	9/16	14.5	7/16	11
4	100	-	10/16	-	15/32	12	13/32	10	19/32	15
4	100	-	-	10	13/32	10	13/32	10	7/16	11
4	100	300	-	-	5/8	16	1-1/6	27	7/16	11
4	100	-	25/40	-	15/32	12	23/32	18	19/32	15
4	100	-	-	16/20	19/32	15	1/2	13	7/16	11
4	100	600	-	-	13/16	20.5	9/16	14.5	7/16	11
4	100	-	-	30	19/32	15	25/32	20	7/16	11
4	100	-	-	40	19/32	15	1-1/32	26	7/16	11
6	150	150	-	-	5/8	16	9/16	14.5	7/16	11
6	150	-	10/16	-	15/32	12	7/16	11	5/8	16
6	150	-	-	10	35/64	14	5/16	8	7/16	11
6	150	-	-	16/20	13/32	10	15/32	12	7/16	11
6	150	300	-	-	11/16	17.5	1-5/16	33.5	7/16	11
6	150	-	25/40	-	15/32	12	3/4	19	5/8	16
6	150	600	-	-	13/16	20.5	9/16	14.5	7/16	11
6	150	-	-	30	43/64	17	1-3/16	30	7/16	11
6	150	-	-	40	43/64	17	1-49/64	45	7/16	11
8	200	150	-	-	5/8	16	1/2	13	5/8	16
8	200	300	-	-	5/8	16	1-1/4	32	5/8	16

**Figure 3: Inlet Companion Flange
“J” Bolt Drilling Instructions**

J-Bolt Drilling

The CSR-7RS fits inside the bolting pattern of the companion flange. The J-Bolt prevents the Safety Head from being installed upside down. The inlet companion flange must be drilled to accept the “J” bolt. Table E lists companion flange drilling dimensions.

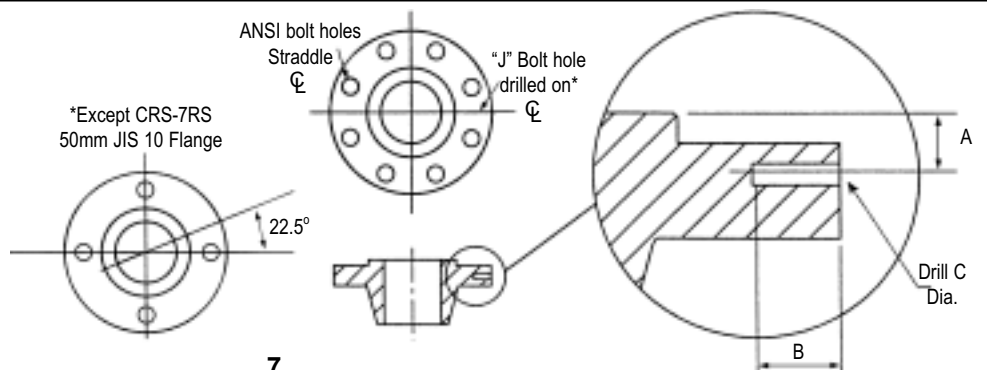

Limitations of Warranties – BS&B Safety Systems, Inc. and BS&B Safety Systems Ltd. warrants their products, when properly installed, used and maintained by the original purchaser, against defective workmanship and materials for a period of twelve (12) months from the date of shipment. Purchaser's failure to use this product in strict compliance with all material operating specifications provided to BS&B Safety Systems, Inc. or BS&B Safety Systems Ltd. by purchaser prior to BS&B Safety Systems, Inc. or BS&B Safety Systems Ltd. production or shipment of this product shall void this warranty. Rupture disks are warranted solely to burst within specified pressure ranges at temperatures specified at the time of sale.

Where pressure relief or other products used by Buyer involve multi-part assemblies, each part must be manufactured by BS&B Safety Systems, Inc. or BS&B Safety Systems Ltd. BS&B Safety Systems, Inc. and BS&B Safety Systems Ltd. specifically disclaim any warranties and any and all liability for damages, either direct or indirect, incidental or consequential, arising from the use of rupture disk assemblies (e.g. rupture disk and rupture disk holder), explosion vent assemblies (e.g. vent and safety frame) or other assemblies not wholly comprised of BS&B Safety Systems, Inc. and BS&B Safety Systems Ltd. manufactured products.

BS&B Safety Systems, Inc. and BS&B Safety Systems Ltd. do not warrant any article not manufactured by BS&B Safety Systems, Inc. or BS&B Safety Systems Ltd. BS&B Safety Systems, Inc. and BS&B Safety Systems Ltd. do not warrant this product against loss or damage caused directly or indirectly by improper pressure relief system design; by the improper use, maintenance or installation (including improper torque) of this product; or by corrosion erosion or malfunction caused by acids, chemicals, fumes, rust, dirt, debris, thermal shock, shock waves or other external agencies over which BS&B Safety Systems, Inc. and BS&B Safety Systems Ltd. have no control.

THE EXPRESSED WARRANTIES HEREIN GIVEN ARE EXCLUSIVE AND IN LIEU OF ALL WARRANTIES EXPRESSED OR IMPLIED, BY OPERATION OF LAW OR OTHERWISE, INCLUDING, WITHOUT LIMITATION, ANY IMPLIED WARRANTY OF MERCHANTABILITY OR FITNESS FOR A PARTICULAR PURPOSE. BUYER'S SOLE AND EXCLUSIVE REMEDY FOR BREACH OF ANY WARRANTY SHALL BE, AT BS&B SAFETY SYSTEMS, INC. OR BS&B SAFETY SYSTEMS LTD. OPTION, THE REPAIR OR REPLACEMENT OF THE PRODUCT, F.O.B. TULSA, OKLAHOMA, OR LIMERICK, IRELAND.

Liability Limitations – BS&B Safety Systems, Inc. and BS&B Safety Systems Ltd. manufacture and supply their products in reliance upon information and specifications provided by its customers. BS&B Safety Systems, Inc. and BS&B Safety Systems Ltd. specifically disclaim any and all liability, of whatever nature, resulting or arising from Buyer's failure to disclose fully all material operating conditions, design parameters, process components, or system or vessel requirements, or from any misrepresentations or omissions by Buyer, Buyer agrees to indemnify and hold harmless BS&B Safety Systems, Inc. or BS&B Safety Systems Ltd. for all costs, loss, liability or damage arising or resulting from BS&B Safety Systems, Inc. or BS&B Safety Systems Ltd. manufacture or supply of this product in accordance with Buyer's specifications or requirements.

BS&B SAFETY SYSTEMS, INC. OR BS&B SAFETY SYSTEMS LTD. AGGREGATE TOTAL LIABILITY TO BUYER FOR ANY AND ALL LOSS OR DAMAGE ARISING OUT OF BUYER'S USE OF, OR INABILITY TO USE, THE PRODUCT SHALL IN NO EVENT EXCEED THE PURCHASE PRICE OF THE PRODUCT OR \$1,000.00, WHICHEVER IS LESSER, BS&B SAFETY SYSTEMS, INC. OR BS&B SAFETY SYSTEMS LTD. SHALL NOT BE LIABLE FOR PERSONAL INJURY OR PROPERTY DAMAGE ARISING OUT OF BUYER'S PURCHASE, INSTALLATION OR USE OF THE PRODUCT, AND IN NO EVENT SHALL BS&B SAFETY SYSTEMS, INC. OR BS&B SAFETY SYSTEMS LTD. BE LIABLE FOR SPECIAL, INCIDENTAL, CONSEQUENTIAL OR PUNITIVE DAMAGES RESULTING FROM ANY SUCH CAUSES.

BS&B Safety Systems, Inc.
7455 East 46th Street
Tulsa, OK 74145
Telephone: 918-622-5950
Facsimile: 918-665-3904
sales@tul.bsbsystems.com
www.bsbsystems.com



BS&B SAFETY SYSTEMS, INC.
BS&B SAFETY SYSTEMS LTD

BS&B Safety Systems Ltd.
Raheen Business Park
Raheen, Limerick, Ireland
Telephone: +353 61 227022
Facsimile: +353 61 227987
sales@bsb.ie
www.bsb.ie



BS&B Safety Systems, Inc. and BS&B Safety Systems Ltd. are here to assist you in providing a safe and efficient work place. For assistance on installation, audits, training or technical advice, please contact our Customer Service Department.